

Mobile Equipment Carriers

Knürr DacoMobile®

Page 5 to 19



Knürr DacoMobile® Strong points

• Stability

- Total load rating of up to 2100 N
- Worktops each with up to 800 N load rating
High stability with low-lying centre of gravity
- Distributed load drawer extension up to 200 N
- Torsional strength with stable aluminium extrusions on die-cast aluminium stabilizers and crosspiece of sheet steel
- Optimal stability for equipment set up in the trolley with raised edges all around the worktop

• Convenience

- Optimised operation with additional module components, such as
 - Cable duct
 - Rear panel
 - Euro mains distributor
 - Master switch
 - Socket strip

- Ergonomically optimal adjustment with
 - Keyboard extension
 - Pull-out shelves
- Effortless management of obstacles and uneven floors with Ø 125 mm large smooth-running castors
- Positioning with 2 lockable castors
- No marks and scratches on the doors, panels and fittings due to the integrated plastic bumper cap

• Variability

- Standard and ESD model components
- Modular designs enable numerous individual models
- Versatile applications ranging from the simple storage trolley to the complex laboratory station
- Simple and quick adjustment without special tools



MOB20095



MOB20053



MOB20096



MOB00274

Dimensions in mm: W = Width
H = Height
D = Depth
h = Installation height
d = Useful depth
L = Length

HU = Standard height unit, 1 HU = 44,45 mm
19" = 482,6 mm, (ideal for 19" components in acc. with DIN 41494)
UP = Unit of packaging
kg = Weight

Conversion: 1 inch = 25,4 mm

Replace „x“ with the number of your color choice

P = assemble to order (shipped within 10 working days)

Caution: In case of larger orders, delivery times may increase.

Knürr DacoMobile® system components Technical data

- Modules can be installed in 50 mm increments in height
- Smooth-running castors, Ø 125 mm, two with stoppers
- **Material**
 - Basic rack consists of:**
 - Extrusions: extruded aluminum
 - Runners: die-cast aluminum
 - Crosspiece: sheet steel
 - Worktop:**
 - sheet steel
 - Other modules:**
 - combination of sheet steel with laminated particle board, or sheet steel.
- **Finish**
 - Metal parts:**
 - powder-coated texture
 - Laminated sheet:**
 - fine-textured
- **Color**
 - Extrusions, runners, castors:**
 - RAL 5003, sapphire blue or RAL 7021 ESD
 - or RAL 7035, light grey
 - Modules:**
 - RAL 7035, light grey
 - ESD castors:**
 - black
- **Maximum static load rating**
 - Per basic rack:**
 - 2,100 N
 - Per castor:
 - 750 N
 - Surface load per worktop:**
 - up to 800 N
- **How supplied**
 - Fully assembled



MOB20051

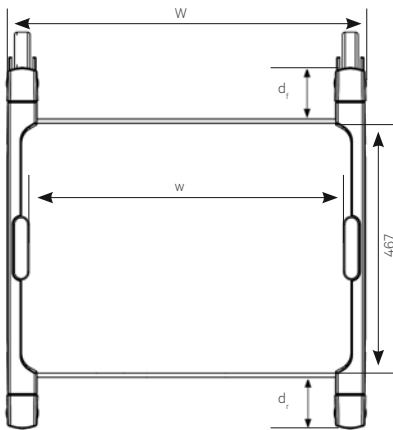

MOB20076

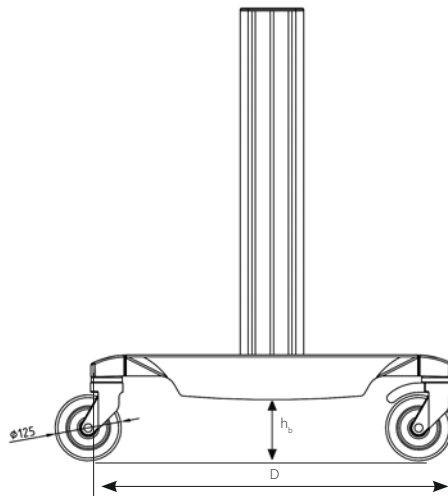

MOB20077

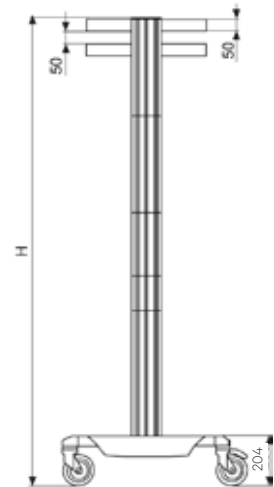

MOB20035

Installation position of the Knürr DacoMobile® elements in 50 mm increments, measured from above.

W (mm)	600	700
w (mm)	496	596

D = 680 mm
 h_b = 120 mm
 d_f = 97 mm
 d_r = 97 mm

Knürr DacoMobile® 1515

- **Material**
 - Worktops – sheet steel
 - Handle(s) – aluminum extrusion
 - Base unit crosspiece – sheet steel
- **Dimensions**
 - Height 1,515 mm
- **Color**
 - RAL 5003, sapphire blue /
 - RAL 7035, light grey
- **Supply schedule**
 - 1 basic rack
 - 2 handles
 - 4 worktops
- **How supplied**
 - Partially assembled

W	H	D	w	Order no.	UP
700	1515	685	596	00.106.628.2	1 unit



MOB20097

Mobile ESD-Measuring and Analysis Station

- **Color combination**
 - Worktop, RAL 7035, light grey
 - Extrusions and stabilizer, RAL 7021 black grey
- **Castor – Ø 125 mm**
- **Load rating**
 - **Basic rack:**
 - 2,100 N
 - **Per castor:**
 - 750 N
 - **Surface load per worktop:**
 - 800 N
- **Material / Finish**
 - **Basic rack consists of:**
 - Extrusions: extruded aluminum
 - Rockers: die-cast aluminum, powder-coated;
 - Sliding handle – aluminum extrusion
 - Base unit crosspiece – sheet steel
 - Drawer unit, sheet steel
 - Table top, sheet steel
- **Supply schedule**
 - 1 ESD-basic rack
 - 2 ESD-worktop
 - 1 ESD-drawer
 - 1 ESD-handle
- **How supplied**
 - Assembled

W	H	D	w	d	Order no.	UP
700	860	685	596	490	00.115.620.9	1 unit



MOB20098

Dimensions in mm: W = Width
 H = Height
 D = Depth
 h = Installation height
 d = Useful depth
 L = Length

HU = Standard height unit, 1 HU = 44,45 mm
 19" = 482,6 mm,
 (ideal for 19" components in acc. with DIN 41494)
 UP = Unit of packaging
 kg = Weight

Conversion: 1 inch = 25,4 mm
 Replace „x“ with the number of your color choice

Knürr DacoMobile® Basic Rack

• Finish

Replace „x“ with the number of your color choice.

Final digit of order number .1:

- Vertical extrusions, die-cast aluminium runners RAL 7035 light grey
- Bottom frame cover RAL 7035 light grey
- Castors, bumper-caps and end-caps black

Final digit of order number .2:

- Vertical extrusions, die-cast aluminium runners RAL 5003 sapphire blue
- Bottom frame cover RAL 7035 light grey
- Castors, bumper-caps and end-caps black
- RAL 5003 sapphire blue

ESD finish .9:

- Vertical extrusions, die-cast aluminum runners RAL7021 black grey, ESD bottom cover RAL 7035, light grey, ESD
- Conductive castors, impact protection caps and end-caps, black

• Supply schedule

- 1 bottom cover made of sheet steel
- 2 die-cast aluminum runners with plastic bumper caps
- 4 smooth-running castors – Ø 125 mm, 2 with snib
- 2 vertical aluminum extrusions with threaded strips for mounting the modules

Design your own individual equipment carrier as follows:

1. Choose ESD or Standard
2. Select a width
3. Select the height of the basic rack
4. Choose the appropriate accessories on the following pages

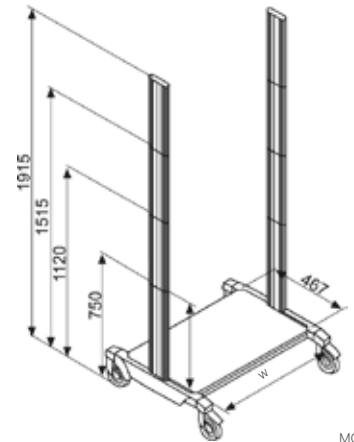

MOB20034

W	H	w	ESD	Order no.	UP
600	750	496		00.101.505.x	1 unit
600	750	496	•	00.101.614.9	1 unit
700	750	596		00.101.605.x	1 unit
700	750	596	•	00.101.615.9	1 unit
600	1120	496		00.103.505.x	1 unit
600	1120	496	•	00.103.614.9	1 unit
700	1120	596		00.103.605.x	1 unit
700	1120	596	•	00.103.615.9	1 unit
600	1515	496		00.104.505.x	1 unit
600	1515	496	•	00.104.614.9	1 unit
700	1515	596		00.104.605.x	1 unit
700	1515	596	•	00.104.615.9	1 unit
600	1915	496		00.105.505.x	1 unit
600	1915	496	•	00.105.614.9	1 unit
700	1915	596		00.105.605.x	1 unit
700	1915	596	•	00.105.615.9	1 unit



MOB00333

Knürr DacoMobile® Cable Duct Large

- With convenient hinged cover with two quicklocks
- Separate cable routing via mounting strip
- Cable exit via sealing lips at any height
- Can be mounted left or right

• Material

- Sheet steel, powder-coated RAL 7035, light grey, antistatic
- ESD: RAL 7021, black-grey, antistatic

• Supply schedule

- 1 cable duct
- Mounting material

W	H	D	ESD	Order no.	UP
85	1120	190		00.118.014.1	1 unit
85	1515	190		00.118.015.1	1 unit
85	1915	190		00.118.016.1	1 unit
85	1120	190	•	00.118.214.9	1 unit
85	1515	190	•	00.118.215.9	1 unit
85	1915	190	•	00.118.216.9	1 unit



MOB20057

Knürr DacoMobile® Castor Set

- Load capacity: 750 N per castor – ø 125 mm
- **Color**
 - **Standard castors:**
 - RAL 5003, sapphire blue
 - **ESD:**
 - Black
- **Supply schedule**
 - 4 smooth-running castors
 - 2 with stopper

ESD	Order no.	UP
	00.128.965.2	1 unit
•	00.128.975.9	1 unit



MOB20067

Knürr DacoMobile® Worktop

- **Material**
 - Sheet steel, powder-coated
- **Color**
 - RAL 7035, light grey
- **ESD version:**
 - RAL 7035, light grey, ESD
- **Supply schedule**
 - 1 worktop
 - Mounting material
- **Note**
 - Please order handle and anti-slide mats separately.

H	D	w	Model	ESD	Order no.	UP
50	490	496	Sheet steel		00.101.530.1	1 unit
50	490	596	Sheet steel		00.101.630.1	1 unit
50	490	496	Sheet steel, ESD	•	00.101.540.1	1 unit
50	490	596	Sheet steel, ESD	•	00.101.640.1	1 unit

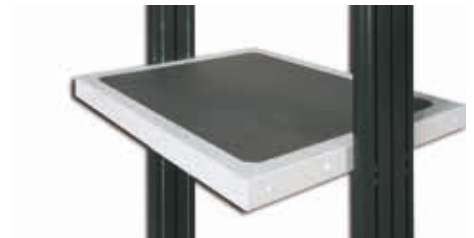

version: sheet steel

MOB20071

Knürr DacoMobile® Worktop Handle

- For sheet steel worktops
- Can be mounted from front and/or rear
- **Material**
 - Sheet steel
 - Aluminum extrusion handle
- **Color**
 - RAL 7035, light grey
- **ESD:**
 - RAL 7021, dark grey, antistatic
- **Supply schedule**
 - 1 handle
 - 2 mounting brackets
 - Mounting material

w	Model	ESD	Order no.	UP
496	Dacomobile worktop handle		00.101.045.1	1 unit
596	Dacomobile worktop handle		00.101.050.1	1 unit
496	Dacomobile worktop handle ESD	•	00.101.145.1	1 unit
596	Dacomobile worktop handle ESD	•	00.101.150.1	1 unit



MOB20070

Dimensions in mm: W = Width
 H = Height
 D = Depth
 h = Installation height
 d = Useful depth
 L = Length

HU = Standard height
 unit, 1 HU = 44.45 mm
 19" = 482.6 mm,
 (ideal for 19" components
 in acc. with DIN 41494)
 UP = Unit of packaging
 kg = Weight

Conversion: 1 inch = 25,4 mm
 Replace „x“ with the number of your
 color choice

Tiltable Mounting Plate

- Universal mounting plate. Can be mounted in three different angle positions
- Maximum static surface load: 20kg

Material

Sheet-steel, powder-coated

Finish

- RAL 7035 light grey

Supply schedule

- 1 mounting plate
- Mounting material

D	w	Order no.	UP
600	496	00.101.134.1	1 unit
600	596	00.101.135.1	1 unit
700	496	00.101.137.1	1 unit
700	596	00.101.138.1	1 unit

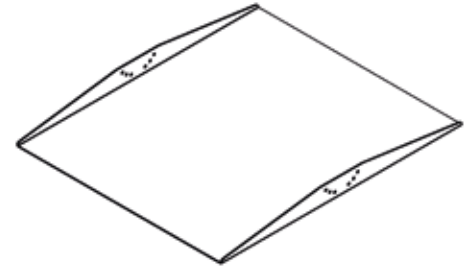

MOB20132

Knürr DacoMobile® Cross Extrusion

- For cross-bracing the basic rack with heavy components or with high carts

Material

- Sheet steel, powder-coated

Finish

Final digit of order number .1:

- RAL 7035 light grey

Final digit of order number .2:

- RAL 5003 sapphire blue

Final digit of order number .9:

- ESD version, RAL 7021 black grey ESD

Supply schedule

- 1 cross extrusion
- Mounting material

w	Model	ESD	Order no.	UP
496	Sheet steel		00.122.510.X	1 unit
596	Sheet steel		00.122.611.X	1 unit
496	Sheet steel, ESD	•	00.122.510.9	1 unit
596	Sheet steel, ESD	•	00.122.611.9	1 unit



MOB20063

Knürr DacoMobile® Telescopic shelf

- ESD or standard version
- Shelf with telescopic slides
- Locking in closed an extended position
- Maximum static load: 22kg

Material

- Sheet steel, powder-coated
- Tray handle – plastic

Color

- Extension board, RAL 7035 light grey, antistatic
- Standard tray handle, RAL 7035 light grey
- ESD handle, black

Supply schedule

- 1 Telescopic shelf, pre-assembled
- Mounting material

H	D	w	Model	ESD	Order no.	UP
50	490	496	Sheet steel		00.125.525.2	1 unit
50	490	596	Sheet steel		00.125.625.2	1 unit
50	490	496	Sheet steel, ESD	•	00.125.530.1	1 unit
50	490	596	Sheet steel, ESD	•	00.125.630.1	1 unit



MOB20050

Dimensions in mm:

W = Width
 H = Height
 D = Depth
 h = Installation height
 d = Useful depth
 L = Length

HU = Standard height unit, 1 HU = 44,45 mm
 19"= 4826 mm,
 (ideal for 19" components in acc. with DIN 41494)
 UP = Unit of packaging
 kg = Weight

Conversion:

1 inch = 25,4 mm

Replace „x“ with the number of your color choice

Knürr DacoMobile® Keyboard Extension Closed

- ESD or standard version
 - Closed sheet steel carcass
 - Main unit cover recessed for optional anti-slide mats
 - Extension board with telescopic slides
 - Mouse table can be moved to the left or right with or without lock
 - Maximum static load for telescopic shelf: 10kg
- **Material**
 - Sheet steel, powder-coated
 - Tray handle – plastic
- **Color**
 - Main unit, extension board, mouse table: RAL 7035, light grey, antistatic
 - Standard tray handle, RAL 7035, light grey
 - ESD handle, black
 - **Supply schedule**
 - 1 keyboard extension, closed, with mouse table
 - Mounting material



MOB20074

H	D	w	Model	ESD	Order no.	UP
100	490	496	With loc		00.127.516.2	1 unit
100	490	596	With loc		00.127.616.2	1 unit
100	490	496	With loc	•	00.127.526.1	1 unit
100	490	596	With loc	•	00.127.626.1	1 unit

Knürr DacoMobile® Drawer Module

- ESD or standard version
 - With or without lock
 - Height – 100 or 150 mm
 - Sheet steel main unit
 - Main unit cover with depression for optional anti-slide mats
 - Maximum static load: 10 kg for drawer 20 kg for corpus
- **Material**
 - Sheet steel, powder-coated
 - Tray handle – plastic
- **Color**
 - Main unit, drawer: RAL 7035, light grey, antistatic
 - Tray handle: Standard RAL 7035, light grey
 - ESD handle: Black
 - **Supply schedule**
 - 1 drawer module
 - Mounting material



MOB20072



MOB20073

H	D	w	Model	ESD	Order no.	UP
100	490	496	With lock		00.117.536.2	1 unit
100	490	596	With lock		00.117.616.2	1 unit
100	490	496	With lock	•	00.117.526.1	1 unit
100	490	596	With lock	•	00.117.626.1	1 unit
150	490	496	With lock		00.117.538.2	1 unit
150	490	596	With lock		00.117.618.2	1 unit
150	490	496	With lock	•	00.117.528.1	1 unit
150	490	596	With lock	•	00.117.628.1	1 unit

Knürr DacoMobile® Storage Tray

- Tray for paper, cables or small parts
 - Height 80 mm
 - With perforation Ø 8 mm
- **Material**
 - Sheet steel, powder-coated
- **Color**
 - RAL 7035, light grey, antistatic
 - **Supply schedule**
 - 1 storage tray
 - Mounting material



MOB20068

H	D	w	Model	ESD	Order no.	UP
80	490	496	ESD	•	00.111.512.1	1 unit
80	490	596	ESD	•	00.111.612.1	1 unit

Knürr DacoMobile® Mounting Kit, Fixed For 19" DoubleProRack Enclosures

- Installation option for two different enclosure depths in the basic rack
- Maximum static load rating, 800 N
- Only for Knürr DacoMobile® width 600 mm!
- Only for Knürr DoubleProRack Enclosure Width 600; depth 500 mm, 600 mm, 700 mm

- **Supply schedule**
 - 1 pair of mounting brackets

- **Note**
More information on 'DoubleProRack':
 - www.pdb.knuerr.com



MOB20067

W	H	D	Order no.	UP
		500	00.101.130.1	1 unit
		600	00.101.131.1	1 unit
		700	00.101.132.1	1 unit



MOB20082

Spacer set for DoubleProRack

- Recommended for DoubleProRack enclosures, mounted in DacoMobile® trolley to stabilize the enclosure

- **Supply schedule**
 - 2x spacer 20mm length
 - 2x Cylinder head screw M6x60
 - 2x Spring nut M6
 - 2x Star washer 6.4mm

- **Material**
 - Aluminium extrusion, powder-coated RAL 7035 light grey

W	H	D	Order no.	UP
			00.101.016.1	1 unit



MOB20133



MOB20134

Vertiv™ Knürr® DoubleProRack® 19" Stand-alone Enclosure

Description

- For components compliant with IEC 297-3
- Side covers and rear panel may be removed
- Flexible assembly of components using T-slot (also available with mounting holes)
- Cable entry via rear panel
- Heat loss discharge via convection on the rear panel (optional with fan unit)

Jumpering space

- Front 125 mm

Load rating

- 1500 N static

Protection rating

- IP 20

Material / Finish

- Covers, sheet steel, powder-coated texture
- Die-cast aluminum frame
- Extruded aluminum extrusions
- Front door glass infill, single safety glass panel

Color

- Panels RAL 7035 light grey
- Frame and extrusions, RAL 5008, grey-blue

Scope of delivery

- 1 x frame rack incl. side covers
- 1 x full glass door
- 1 x rear panel with cable entry, 3 parts
- 1 x panel, above, with vent slots
- 1 x panel, below, with vent slots
- 1 x 19" component set (4 vertical extrusions with T-slot)
- 1 x grounding set with M8 grounding bolt

How supplied

- Assembled

Note

- When using a DoublePro rack in combination with a DacoMobile, we recommend to choose the DacoMobile in color combination .1 (light grey)



DOP00256

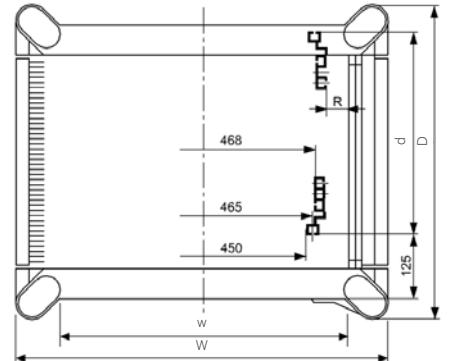
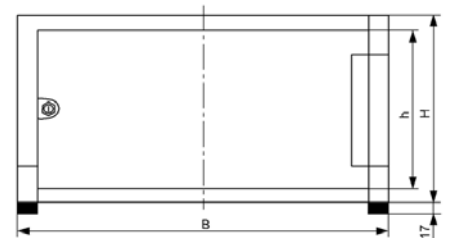

DOP00230

W	H	D	U	h	d (max.)	Model	Order no.	UP
554.4	577	600	12	532	435	With full glass door	01.246.643.1	1 unit
554.4	711	600	15	666	435	With full glass door	01.246.644.1	1 unit
554.4	844	600	18	799	435	With full glass door	01.246.645.1	1 unit
554.4	978	600	21	932	435	With full glass door	01.246.646.1	1 unit
554.4	1111	600	24	1066	435	With full glass door	01.246.647.1	1 unit

Dimensions in mm: W = Width
 H = Height
 D = Depth
 h = Installation height
 d = Useful depth
 L = Length

HU = Standard height unit, 1 HU = 44,45 mm
 19" = 482,6 mm, (ideal for 19" components in acc. with DIN 41494)
 UP = Unit of packaging
 kg = Weight

Conversion: 1 inch = 25,4 mm
 Replace „x“ with the number of your color choice

Vertiv™ Knürr® DoubleProRack® 19" Enclosure without Front Door

Description

- For components compliant with IEC 297-3
- Side covers and rear panel may be removed
- Heat loss discharge via convection on the rear panel (optional with fan unit)

Load rating

- 1500 N static

Protection rating

- IP 20

Material / Finish

- Covers, sheet steel, powder-coated texture
- Die-cast aluminum frame
- Extruded aluminum extrusions

Color

- Panels RAL 7035 light grey
- Frame and extrusions, RAL 5008, greyblue

Scope of delivery

- 1 x frame rack incl. side covers
- 1 x panel, above, with vent slots
- 1 x panel, below, with vent slots
- 1 x rear panel (from 12 U enclosure height incl. 3 U vented cover plate)
- 2 x 19" extrusions, front, with mounting holes
- 2 x 19" extrusions at the rear, T-slot

How supplied

- Assembled

Note

- When using a DoublePro rack in combination with a DacoMobile, we recommend to choose the DacoMobile in color combination .1 (light grey)

W	H	D	U	h	d (max.)	Kg	Model	Order no.	UP
554.4	311	500	6	265	460	12.5	Without door	01.243.506.1	1 unit
554.4	444	500	9	399	460	15.0	Without door	01.243.509.1	1 unit
554.4	577	500	12	532	460	17.0	Without door	01.243.512.1	1 unit
554.4	711	500	15	666	460	19.5	Without door	01.243.515.1	1 unit
554.4	311	600	6	265	560	14.0	Without door	01.243.606.1	1 unit
554.4	444	600	9	399	560	16.5	Without door	01.243.609.1	1 unit
554.4	577	600	12	532	560	19.0	Without door	01.243.612.1	1 unit
554.4	711	600	15	666	560	22.0	Without door	01.243.615.1	1 unit
554.4	844	600	18	799	560	24.5	Without door	01.243.618.1	1 unit
554.4	978	600	21	932	560	27.0	Without door	01.243.621.1	1 unit
554.4	1111	600	24	1066	560	29.5	Without door	01.243.624.1	1 unit
554.4	577	700	12	532	660	21.5	Without door	01.243.712.1	1 unit
554.4	711	700	15	666	660	24.0	Without door	01.243.715.1	1 unit
554.4	844	700	18	799	660	27.0	Without door	01.243.718.1	1 unit
554.4	978	700	21	932	660	29.5	Without door	01.243.721.1	1 unit
554.4	1111	700	24	1066	660	32.5	Without door	01.243.724.1	1 unit



DOP00253

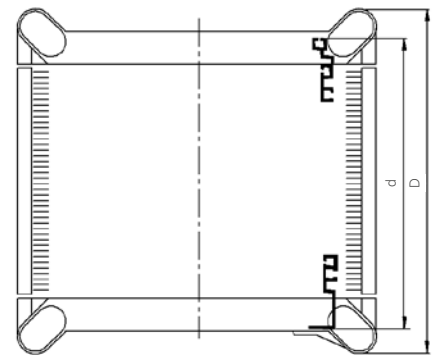
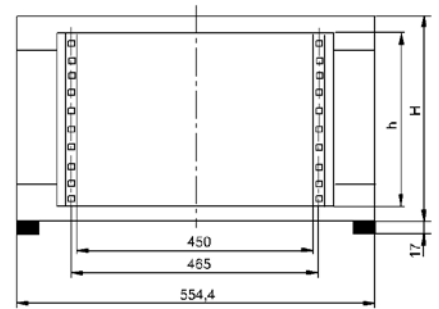

DOP00052

Dimensions in mm:

W = Width
 H = Height
 D = Depth
 h = Installation height
 d = Useful depth
 L = Length

HU = Standard height unit, 1 HU = 44.45 mm
 19" = 482.6 mm, (ideal for 19" components in acc. with DIN 41494)

UP = Unit of packaging
 kg = Weight

Conversion:

1 inch = 25.4 mm

Replace „x“ with the number of your color choice

Vertiv™ Knürr® DoubleProRack® 19" Installation, Front with T-slot

- Can also be used as second mounting level
- **Material**
 - Aluminum extrusions
- **Finish**
 - Polished
- **Scope of delivery**
 - 2 x 19" extrusions at the front, T-slot
 - 1 x Mounting kit
- **How supplied**
 - In sets

U	Order no.	UP
6	01.240.440.9	1 set
9	01.240.443.9	1 set
12	01.240.445.9	1 set
15	01.240.446.9	1 set
18	01.240.447.9	1 set
21	01.240.448.9	1 set
24	01.240.449.9	1 set

Vertiv Knürr DoubleProRack 19" Installation, Front with Mounting Holes

- Can also be used as second mounting level
- **Material**
 - Extruded aluminum extrusions
- **Finish**
 - Polished
- **Scope of delivery**
 - 2 x 19" extrusions at the front, mounting holes
- **How supplied**
 - In sets

U	Order no.	UP
6	01.240.490.9	1 set
9	01.240.493.9	1 set
12	01.240.495.9	1 set
15	01.240.496.9	1 set
18	01.240.497.9	1 set
21	01.240.498.9	1 set
24	01.240.499.9	1 set

Vertiv Knürr DoubleProRack Fan Rear Panel 3 U

- With axial fans
- With thermostat
- **Technical data for single fan**
 - Max. volume flow (free blowing):**
 - 162 m³/h
 - Noise emission (free blowing):**
 - 37 dB(A)
- **Technical data for thermostat**
 - Setting range:**
 - 0 to 60°C
 - Mains supply:**
 - 240 V / 50 Hz
 - Nominal current:**
 - 16 A
- **Scope of delivery**
 - 1 x fan rear panel, wired
 - 1 x Mounting kit
- **Finish / Color**
 - Powder-coated texture, RAL 7035 light grey
- **How supplied**
 - Assembled
- **Note**
 - Cannot be used in the enclosure's lowest U

W	H	U	Model	Order no.	UP
554.4	132.5	3	With thermostat	01.243.428.1	1 unit



DOP20004

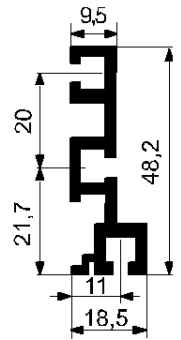

DOP00313



DOP20005

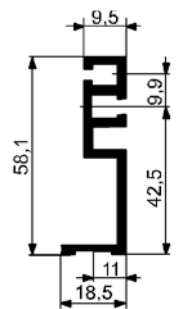

DOP00055



DOP20035



DOP20036

Vertiv Knürr DoubleProRack Rear Panel, closed

- For DoubleProRack width 554.4 mm
- **Material / Finish**
 - Sheet steel, 0.8 mm, powder-coated texture
- **Color**
 - RAL 7035, light grey

- **Scope of delivery**
 - 1 x rear panel, closed
 - 1 x Mounting kit
- **How supplied**
 - In sets

W	U	Order no.	UP
554.4	6	01.240.454.1	1 unit
554.4	9	01.240.457.1	1 unit
554.4	12	01.240.459.1	1 unit
554.4	15	01.240.460.1	1 unit
554.4	18	01.240.461.1	1 unit
554.4	21	01.240.462.1	1 unit



DOP00275

Vertiv™ Knürr® DoubleProRack® Connection Panel with Brush Strip

- To cover rear panel along with the corresponding rear panel shortened by 3 U
- For DoubleProRack width 554.4 mm
- With brush strip for cable routing and strain relief
- **Finish / Color**
 - Powder-coated texture, RAL 7035 light grey

- **Scope of delivery**
 - 1 x connection plate
 - 1 x Mounting kit
- **How supplied**
 - In sets

W	H	U	Order no.	UP
554.4	132.5	3	01.243.438.1	1 unit



DOP00274

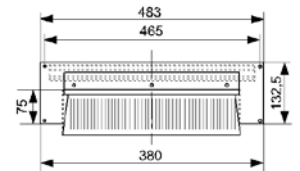

DOP00288

Grounding Bar

- For safe grounding or potential equalization of equipment and components
- **Material**
 - Electrolyte copper 9 x 9

- **Scope of delivery**
 - 1 x grounding bar
 - 2 x brackets
 - 1 x Mounting kit

U	Order no.	UP
12	01.110.703.9	1 unit
21	01.240.545.9	1 unit



ELM00068

Vertiv Knürr DoubleProRack Grounding Set for Enclosures

- For grounding top/bottom cover
- With central grounding bolt
- **Scope of delivery**
 - 2 x grounding connections, length 250 mm
 - 4 x spring nuts, M5
- **How supplied**
 - 2 x washers
 - 4 x cylinder screws, M5 x 10
 - 1 x grounding bolt
 - In sets

Order no.	UP
01.243.400.9	1 set

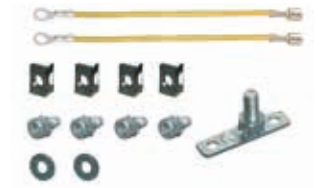

MEC20122



DOP20025

Vertiv Knürr DoubleProRack Grounding Set for Doors and Trims

- For grounding doors and/or cover plates
- **Scope of delivery**
 - 5 x grounding connections, length 250 mm
 - 1 x grounding connection, 250 mm, two-sided AMP plug
 - 5 x spring nuts, M5
- **How supplied**
 - 5 x cylinder screws, M5 x 10 with tooth-lock washer
 - 5 x washers
 - In sets

Order no.	UP
01.245.400.9	1 set



MEC20123



DOP00286

Contact Clamp

- Enables safe connection of equipment and components to grounding bar
- For cables up to 25 mm
- **Scope of delivery**
 - 120 x contact clamps

Order no.	UP
01.110.715.9	20 units



DOP20016

Dimensions in mm: W = Width
 H = Height
 D = Depth
 h = Installation height
 d = Useful depth
 L = Length

HU = Standard height unit, 1 HU = 44.45 mm
 19" = 482.6 mm,
 (ideal for 19" components in acc. with DIN 41494)
 UP = Unit of packaging
 kg = Weight

Conversion: 1 inch = 25.4 mm
 Replace „x“ with the number of your color choice

ESD mounting set for isolating transformer

- Tray: Mount on underside of base unit
 - Secure fixing of the isolating transformers
 - With ventilation perforations
- **Material**
 - Sheet steel, powder-coated
 - **Color**
 - RAL 7035, light grey, antistatic
- **Supply schedule**
 - 1 mounting set
 - Mounting material
 - **Note**
 - **Only for Knürr Dacomobile:**
W 696 mm, w 596 mm

W	H	D	Model	Order no.	UP
520	120	350	Tray	00.101.262.1	1 unit



MOB20064

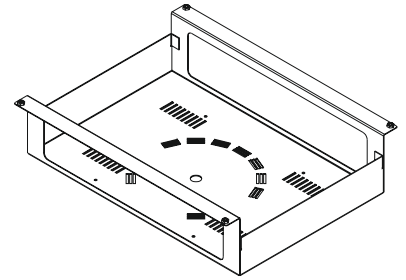

Knürr DacoMobile® Master Switch Module

- For mounting on the vertical extrusions
 - With lit on/off switch, white
 - Pre-wired with H05VV-F3G cable, 1.5 mm²
 - Sheet steel, powder-coated
- **Color**
 - **Standard:**
 - RAL 7035, light grey, antistatic
 - **Supply schedule**
 - 1 master switch module
 - Mounting material

W	H	D	Order no.	UP
40	76	90	00.118.001.1	1 unit



MOB20048

Knürr DacoMobile® Rubber Mat

- **Material**
 - Self-adhesive rubber-mat made of open pore sponge rubber
- **Colour**
 - Standard: grey, ESD: black

W	w	Model	ESD	Order no.	UP
600	496	Standard, for sheet-steel table top and drawer unit top		00.101.195.0	1 unit
700	596	Standard, for sheet-steel table top and drawer unit top		00.101.200.9	1 unit
600	496	Standard, for sheet-steel keyboard extension open		00.101.196.0	1 unit
700	596	Standard, for sheet-steel keyboard extension open		00.101.202.9	1 unit
600	496	ESD, for sheet-steel tabletop and drawer unit top	•	00.101.198.0	1 unit
700	596	ESD, for sheet-steel tabletop and drawer unit top	•	00.101.208.9	1 unit
600	496	ESD, for sheet-steel keyboard extension open	•	00.101.199.0	1 unit
700	596	ESD, for sheet-steel keyboard extension open	•	00.101.210.9	1 unit

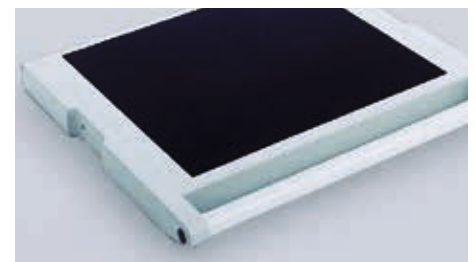

MOB00298

Dimensions in mm: W = Width
H = Height
D = Depth
h = Installation height
d = Useful depth
L = Length

HU = Standard height unit, 1 HU = 44.45 mm
19" = 482.6 mm,
(ideal for 19" components in acc. with DIN 41494)
UP = Unit of packaging
kg = Weight

Conversion: 1 inch = 25,4 mm
Replace „x“ with the number of your color choice

Knürr DacoMobile® 19"

- **Color**
 - RAL 5003, sapphire blue / RAL 7035 light grey
- **Supply schedule**
 - 1 Basic rack
 - 1 Cross extrusion
- **How supplied**
 - 2 19" Extrusions
 - 10 Chassis runners
 - Part assembled

W	H	D	HU/U	h	Order no.	UP
606	1865	685	36	1600	01.316.016.2	1 unit
606	2000	685	39	1733	01.316.019.2	1 unit



MOB00402

Knürr DacoMobile® Chassis Runner Set For mounting 19" equipment

- **Material**
 - Sheet steel, zinc passivated
- **Supply schedule**
 - 2 Chassis runners
 - Mounting material
- **Dimensions**
 - Length:**
 - 200 mm
 - Thickness:**
 - 2 mm
 - Angle bracket:**
 - 44 x 50 mm

W	H	D	Order no.	UP
50	44	200	01.316.026.7	1 unit



MOB00336