



VERTIV™

KNÜRR® CONSOLES

Knürr® CEC - Console Environment Control



KNÜRR® CEC - CONSOLE ENVIRONMENT CONTROL

For maximum reliability and control of your 24/7 equipment in the console

Whether in the emergency call centre, in the industrial control room or in the surveillance control room, high-availability technology is in use everywhere around the clock. The investments for this are considerable, and every component from the power supply to the image output device is crucial for the availability of the systems.

Protect your IT investments with the Knürr® Console Environment Control (CEC) and always maintain control and an overview.

The Knürr® CEC is much more than a power supply and distribution in the console! Equipped with a network interface, it enables remote monitoring and management as well as automatic notifications. The Knürr® CEC provides important insights into how you can improve energy efficiency in the control room while avoiding downtime.

If user-defined limit values for e.g. temperature or current are exceeded, you immediately receive a notification and thus maintain a complete overview in the network of devices.

POWER



INTEGRATION



MONITORING & SURVEILLANCE



Device Director

Device Director is a comprehensive, Windows-based utility that is used to install, configure and maintain multiple Knürr® CEC devices within a single interface.

Device Director helps you set the IP addresses of multiple devices, configure user accounts, modify network settings, update firmware, export/import configuration settings and validate device connectivity.

Device Director provides you with a powerful and simple way to configure the devices and effectively reduce setup time and maintenance costs.

- Automatic detection in the network
- Mass configuration of device and network settings
- Bulk firmware updates



Knürr® CEC Unit

Remote monitoring and management through integrated network interface and automatic notifications.

Temperature sensor

For easy monitoring of the temperature in the technical area.

Door Position

The RDPS detects whether a panelling of the technical area is open or closed, e.g. during maintenance work.

Temperature/ Humidity/ Dew Point/ Airflow

The RTAFHD3 sensor provides important information to prevent premature unit failure due to out-of-range operating conditions.

Analog-to-Digital Converter

allows users to connect a dry contact, 0-10V, or 4-20mA sensor to an RJ12/ Plug-n-Play sensor port.

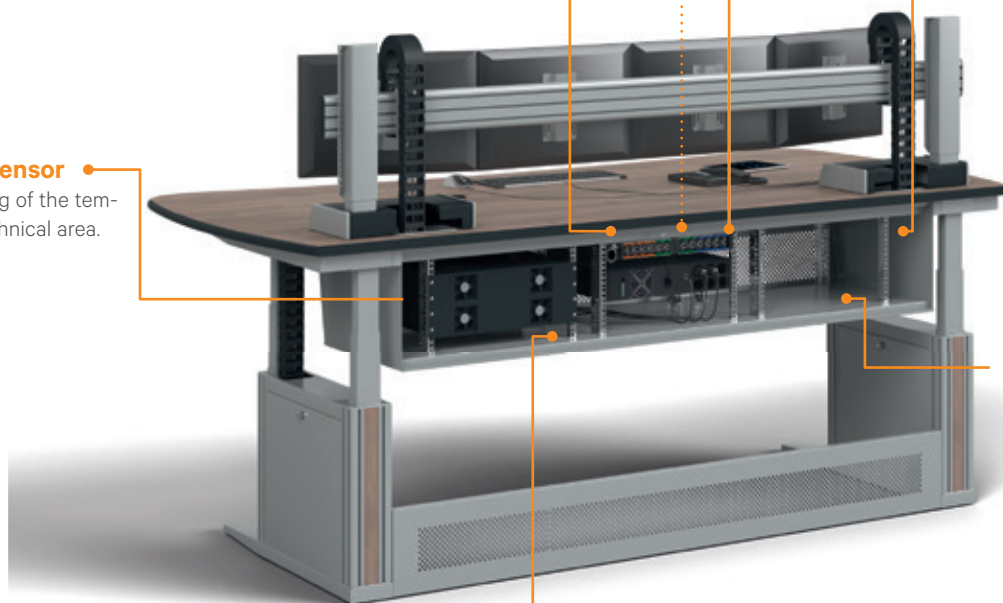



Environmental Monitoring

Proactively monitor environmental conditions in the console to ensure optimal operating conditions. A variety of sensors are available to meet your needs, including temperature, humidity, airflow, door position and more.



Remote Connectivity

Access the Knürr® CEC remotely via the network interface or a serial connection to monitor power consumption and configure custom alerts to avoid downtime.



Fault-Tolerant Daisy Chaining

Simplifies intelligent connectivity and ensures data is reported even when a break in the network chain occurs.



Combination Outlet C13 / C19

Both C14 (10A) and C20 (16A) IEC plugs can be plugged into the combination socket.



Power Monitoring 1% accuracy

Allows to accurately monitor input and outlet level power usage with 1% monitoring accuracy tested to ANSI and IEC standards.



U-Lock

Secure power cords and avoid accidental disconnections. Receptacles are color-coded by circuit for instant identification.

Vertiv™ Intelligence Director

Daisy-chain up to 50 devices on a single IP address. Reduce deployment time with self-configuration of downstream devices.



Knürr CEC Intelligence Director

PLUG-N-PLAY INFRASTRUCTURE FOR CONTROL ROOMS ENABLES A LIGHTNING-FAST READY

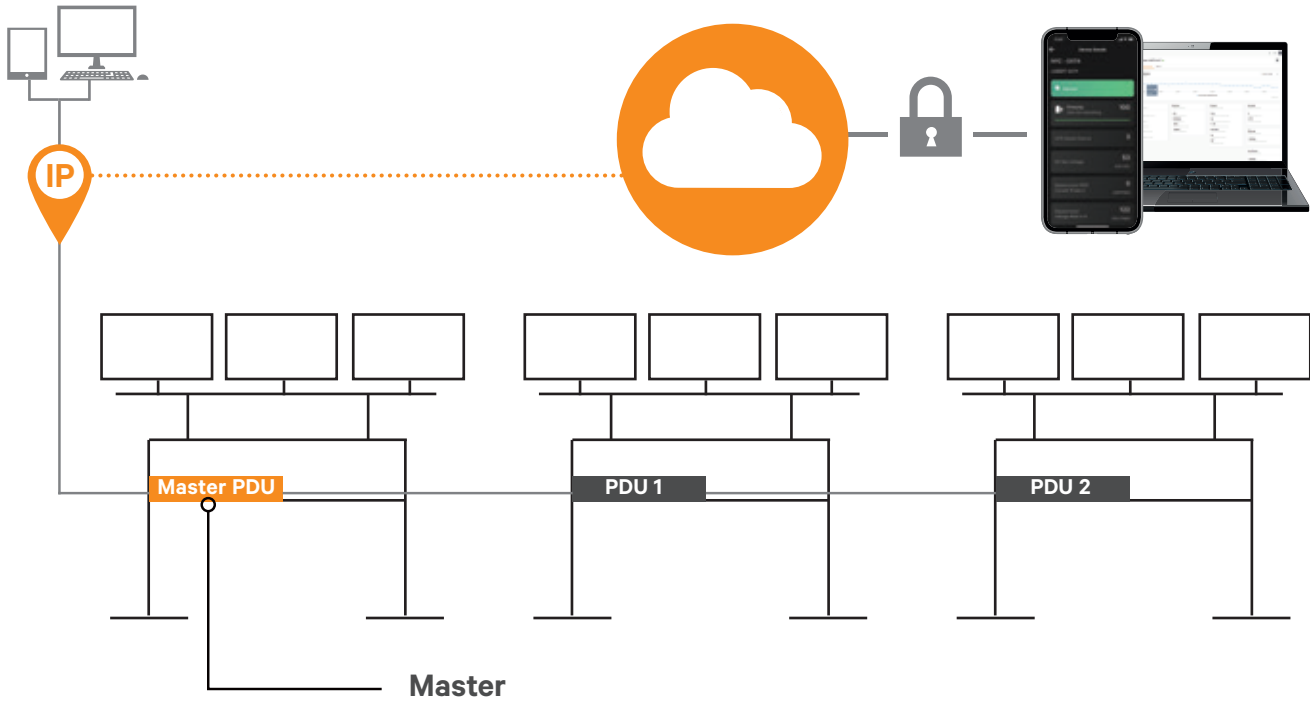

- On Monitored and Switched units, users have the ability to daisy chain up to 50 devices with a single IP address.
- Users are able to bundle data by grouping devices by console or room.
- Downstream devices self-configure, significantly reducing deployment time.

Convenient browser-based application

State	Label	Energy (kWh)	Real Power (W)	Apparent Power (VA)	Power Factor (%)	Voltage (V _{line})	Current (A _{line})	Current Crest Factor	Balance (%)
	Feed A	499.9	393	480	81	223.7	2.15	2.44	100

State	Label	Current (A _{line})
	Phase 1 inaktiv	0.00
	Phase 2 inaktiv	0.00
	Phase 3 aktiv	2.13

State	Label	Mode	Value
	Analog Input	Door	Open

State	Label	Temperature (C)	Humidity (%)	Dewpoint (C)
	Main Temp Console 1	23.10	28	3.61
	Server Compartment	22.88		
	Workstation Compartment	32.25		

Perfect overview

Thanks to the convenient browser-based management of the Knürr® CEC units, you always have an overview of the relevant values and environment variables.

Knürr CEC – Console Environment Control

OVERVIEW

	SINGLE PHASE MONITORED		3 PHASE MONITORED	3 PHASE SWITCHED		
						
System Features	UR30200	UI30027L	GR30200	GS30200	GU30200	
Monitoring	Input and Outlet power monitoring. Environmental monitoring via optional remote sensors. Daisy chain Ethernet connectivity. Local high visibility LED display.	Input power monitoring. Environmental monitoring via optional remote sensors. Daisy chain Ethernet connectivity. Local high visibility LED display.	Input and Outlet power monitoring with Outlet switching. Circuit/Breaker current monitoring. Environmental monitoring via optional remote sensors. Daisy chain Ethernet connectivity. Local high visibility LED display.	Input power monitoring with Outlet switching. Circuit/Breaker current monitoring. Environmental monitoring via optional remote sensors. Daisy chain Ethernet connectivity. Local high visibility LED display.	Input and Outlet power monitoring with Outlet switching. Circuit/Breaker current monitoring. Environmental monitoring via optional remote sensors. Daisy chain Ethernet connectivity. Local high visibility LED display.	
Input Monitoring	Phase (A) Monitoring (kWh, W, VA, PF, V, A) Power Measurements Compliant with ANSI C12.1 and IEC 62053-21 at 1% Accuracy Class Requirements	Phase (A) Monitoring (kWh, W, VA, PF, V, A) Power Measurements Compliant with ANSI C12.1 and IEC 62053-21 at 1% Accuracy Class Requirements	Total Unit Monitoring (kWh, W, VA, PF) Phase (A, B, C) Monitoring (kWh, W, VA, PF, V, A) Power Measurements Compliant with ANSI C12.1 and IEC 62053-21 at 1% Accuracy Class Requirements	Total Unit Monitoring (kWh, W, VA, PF) Phase (A, B, C) Monitoring (kWh, W, VA, PF, V, A) Power Measurements Compliant with ANSI C12.1 and IEC 62053-21 at 1% Accuracy Class Requirements	Total Unit Monitoring (kWh, W, VA, PF) Phase (A, B, C) Monitoring (kWh, W, VA, PF, V, A) Power Measurements Compliant with ANSI C12.1 and IEC 62053-21 at 1% Accuracy Class Requirements	
Outlet Monitoring	Outlet Monitoring (kWh, W, VA, PF, V, A) Power Measurements Compliant with ANSI C12.1 and IEC 62053-21 at 1% Accuracy Class Requirements.	–	Outlet Monitoring (kWh, W, VA, PF, V, A) Power Measurements Compliant with ANSI C12.1 and IEC 62053-21 at 1% Accuracy Class Requirements.	–	Outlet Monitoring (kWh, W, VA, PF, V, A) Power Measurements Compliant with ANSI C12.1 and IEC 62053-21 at 1% Accuracy Class Requirements.	
Voltage	100-240V	100-240V	200-240/346-415V WYE	200-240/346-415V WYE	200-240/346-415V WYE	
Current	16A or 20A	16A or 20A	16A x 3 Phase WYE	16A x 3 Phase WYE	16A x 3 Phase WYE	
Power Cable Wire Gauge and Length	Cord sold separately	Cord sold separately	2.5mm² H07RN-F 10ft / 3m	2.5mm² H07RN-F 10ft / 3m	2.5mm² H07RN-F 10ft / 3m	
Plug Type	IEC60320 C20 Power Inlet (cord sold separately)	IEC60320 C20 Power Inlet (cord sold separately)	IEC60309 3P + N + E, 16A, 230/400V, Splashproof IP44	IEC60309 3P + N + E, 16A, 230/400V, Splashproof IP44	IEC60309 3P + N + E, 16A, 230/400V, Splashproof IP44	
	Plug Form: Receptacle:  C20 Combination C13/C19 (Quantity: 12)		Plug Form: Receptacle:  3P+N+E (IP44) Combination C13/C19 (Quantity: 12)		Plug Form: Receptacle:  3P+N+E (IP44) Combination C13/C19 (Quantity: 12)	
	Plug Form: Receptacle:  C20 Inlet Locking IEC C13 (Quantity: 10)					
Item number	UR30200	UI30027L	GR30200	GS30200	GU30200	

Dimensions in mm: W = Width
 H = Height
 D = Depth
 h = Installation height
 d = Useful depth
 L = Length

HU = Standard height unit, 1 HU = 44.45 mm
 19" = 482.6 mm.
 (ideal for 19" components in acc. with DIN 41494)
 UP = Unit of packaging

Conversion: 1 inch = 25.4 mm

Integrate Environmental Sensors to Pro-actively Monitor Critical Infrastructure



Temperature — SRT

The SRT is an easy-to-install external temperature sensor great for monitoring a variety of areas, such as; A/C inlet, A/C outlet, ambient room temperature, hot spots, and internal cabinet temperature. The SRT is available in a variety of cable lengths. Contact a Vertiv sales representative for a full list of temperature sensor options.

Length	Order no.	UP
3.6 m (also available in 6m or 15m)	SRT-12	1 unit



Temperature/ Humidity/ Dew Point/ Airflow — RTAFHD3

The RTAFHD3 temperature, relative humidity, dew point, and airflow sensor provides critical information to ensure equipment is receiving adequate airflow within the optimal parameters to prevent premature equipment failure due to out-of-range operating conditions.

Length	Order no.	UP
3.6 m (also available in 6m or 15m)	RTAFHD3-12	1 unit



Temperature/ Humidity/ Dew Point — GTHD

The GTHD sensor collects and transmits real-time temperature and relative humidity data to protect critical data center and Edge infrastructure from heat and moisture. The sensors can be daisy chained together to simplify installation.

Length	Order no.	UP
3 m	GTHD	1 unit



Temperature x 3/ Humidity/ Dew Point Kit — GT3HD

The GT3HD provides real-time temperature and relative humidity monitoring with additional 3ft/ .9m and 6ft/ 1.8m temperature sensors. The GT3HD is ideal for monitoring temperature at the top, middle, and bottom of a server cabinet. A supplementary input provides the ability to daisy-chain additional sensors together making it a perfect solution for monitoring a row of racks or cabinets.

Length	Order no.	UP
3 m	GT3HD	1 unit



Analog-to-Digital Converter — A2D

The A2D allows users to connect a dry contact, 0-10V, or 4-20mA sensor to an RJ12/ Plug-n-Play sensor port. It provides users with the flexibility to utilize a Plug-n-Play sensor port for a Dry Contact / 0-5V sensor.

Length	Order no.	UP
3 m	A2D-10	1 unit



Door Position — RDPS

The RDPS detects when a door or cabinet is open or closed. The door position sensor has four components: magnet, switch with screw-terminal, cover and connection wires. The wired switch is mounted to the door frame or cabinet and the magnet on the door, opposite the switch. When the door is opened, the switch separates and the sensor trips an alarm.

Length	Order no.	UP
9 m	RDPS	1 unit



[knuerr-consoles.com](https://www.knuerr-consoles.com) | Vertiv Integrated Systems GmbH, Mariakirchener Straße 38, 94424 Arnstorf, Germany ID-Nr. DE 129273873, WEEE DE14390867

© 2021 Vertiv Group Corp. All rights reserved. Vertiv™ and the Vertiv logo are trademarks or registered trademarks of Vertiv Group Corp. All other names and logos referred to are trade names, trademarks or registered trademarks of their respective owners. While every precaution has been taken to ensure accuracy and completeness herein, Vertiv Group Corp. assumes no responsibility, and disclaims all liability, for damages resulting from use of this information or for any errors or omissions. Specifications are subject to change without notice.